

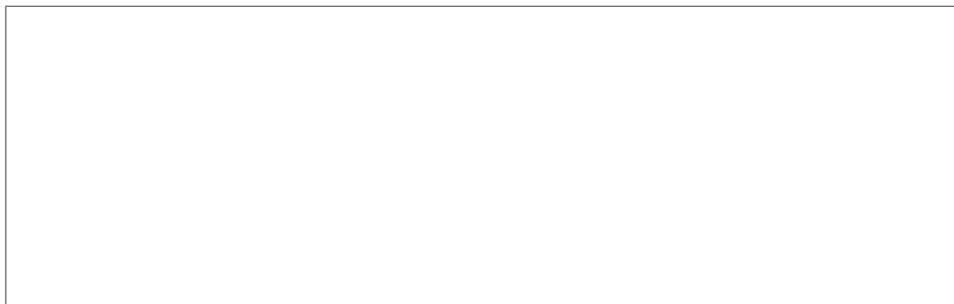

**BUILT-IN
COOKING HOBS
- P60**



Instructions for the use - Installation advices
KEEP IN A SAFE PLACE

Before operating this hob,
please read these instructions carefully

Dear Customer,

Thank you for having purchased and given your preference to our product.

The safety precautions and recommendations given below are for your own safety and that of others. They will also provide a means by which to make full use of the features offered by your appliance.

Please keep this booklet carefully. It may be useful in future, either to yourself or to others if doubts should arise relating to its operation.

This appliance must be used only for the task it has explicitly been designed for, that is for cooking foodstuffs.

Any other form of usage is to be considered as inappropriate and therefore dangerous.

The manufacturer declines all responsibility in the event of damage caused by improper, incorrect or unreasonable use of the appliance.

DECLARATION OF CE CONFORMITY

- This appliance has been designed to be used only for cooking. Any other use (such as heating a room) is improper and dangerous.
- This appliance has been designed, constructed, and marketed in compliance with:
 - Safety requirements of EU Directive "Gas" 90/396/EEC;
 - Safety requirements of EU Directive "Low Voltage" 2006/95/EC;
 - Protection requirements of EU Directive "EMC" 89/336/EEC;
 - Requirements of EU Directive 93/68/EEC.



IMPORTANT PRECAUTIONS AND RECOMMENDATIONS

- ✓ After having unpacked the appliance, check to ensure that it is not damaged.
If you have any doubts, do not use it and consult your supplier or a professionally qualified technician.
- ✓ Packing elements (i.e. plastic bags, polystyrene foam, nails, packing straps, etc.) should not be left around within easy reach of children, as these may cause serious injuries.
- ✓ The packaging material is recyclable and is marked with the recycling symbol .
- ✓ Do not attempt to modify the technical characteristics of the appliance as this may become dangerous to use.
- ✓ The appliance was designed for non-professional use by private individuals in communal dwellings.
- ✓ The manufacturer cannot be considered responsible for damage caused by unreasonable, incorrect or rash use of the appliance.
- ✓ If you should decide not to use this appliance any longer (or decide to substitute an older model), before disposing of it, it is recommended that it be made inoperative in an appropriate manner in accordance to health and environmental protection regulations, ensuring in particular that all potentially hazardous parts be made harmless, especially in relation to children who could play with old appliances.
- ✓ The appliance should be installed and all the gas/electrical connections made by a qualified engineer in compliance with local regulations in force and following the manufacturer's instructions.

For European Union countries only:

These instructions are only valid for the countries indicated by the symbols on the cover of the instruction booklet and on the appliance itself.

IMPORTANT INFORMATION FOR CORRECT DISPOSAL OF THE PRODUCT IN ACCORDANCE WITH EC DIRECTIVE 2002/96/EC.

(for European Union countries only - models with electric hotplates)

At the end of its working life, the product must not be disposed of as urban waste. It must be taken to a special local authority differentiated waste collection centre or to a dealer providing this service.

Disposing of a household appliance separately avoids possible negative consequences for the environment and health deriving from inappropriate disposal and enables the constituent materials to be recovered to obtain significant savings in energy and resources. As a reminder of the need to dispose of household appliances separately, the product is marked with a crossed-out wheeled dustbin.



TIPS FOR THE USER

- ✓ During and after use of the cooktop, certain parts will become very hot. Do not touch hot parts.
- ✓ Keep children away from the cooking hob when it is in use.
- ✓ After use, ensure that the knobs are in position ● (off), and close the main gas delivery valve or the gas cylinder valve.
- ✓ When the appliance is not being used, it is advisable to keep the gas tap closed.
- ✓ The periodic lubrication of the gas taps must be done only by specialized personnel. In case of difficulty in the gas taps operation, call Service.
- ✓ Make sure that the electrical cables of other appliances installed nearby cannot come into contact with the cooktop.

IMPORTANT PRECAUTIONS AND RECOMMENDATIONS FOR USE OF ELECTRICAL APPLIANCES

Use of any electrical appliance implies the necessity to follow a series of fundamental rules. In particular:

- ✓ Never touch the appliance with wet hands or feet;
- ✓ do not operate the appliance barefooted;
- ✓ do not allow children or disabled people to use the appliance without your supervision.

The manufacturer cannot be held responsible for any damages caused by improper, incorrect or unreasonable use of the appliance.

CAUTION:

If the burner is accidentally extinguished, turn the gas off at the control knob and wait at least 1 minute before attempting to relight.

CAUTION:

Gas hobs produce heat and humidity in the environment in which they are installed. Ensure that the cooking area is well ventilated by opening the natural ventilation grilles or by installing an extractor hood connected to an outlet duct.

CAUTION:

If the hob is used for a prolonged time it may be necessary to provide further ventilation by opening a window or by increasing the suction power of the extractor hood (if fitted).

1

FEATURES

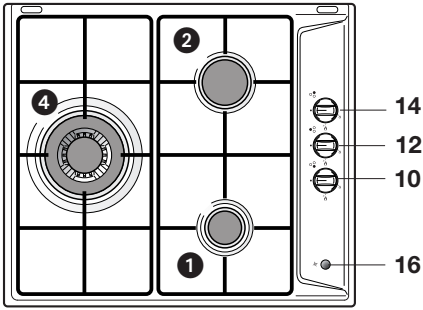

Fig. 1.1a

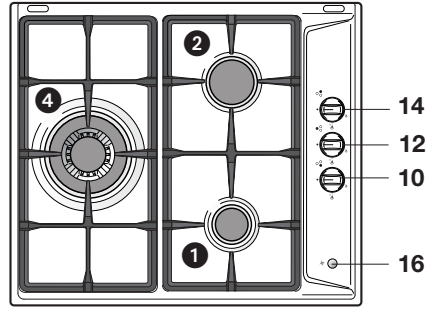

Fig. 1.1b

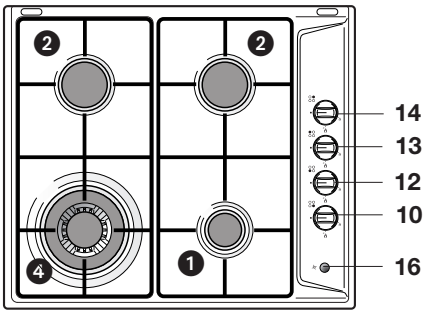

Fig. 1.2a

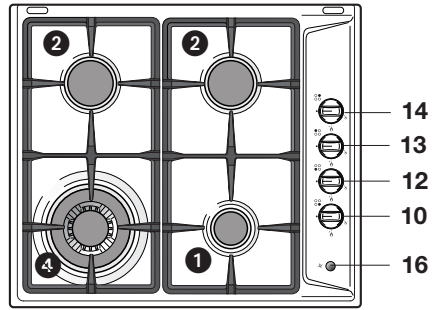

Fig. 1.2b

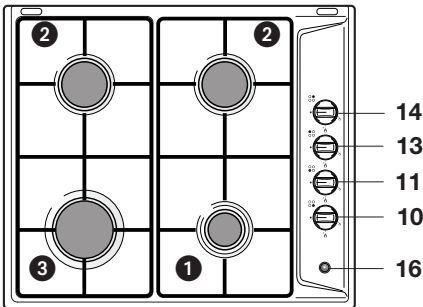

Fig. 1.3a

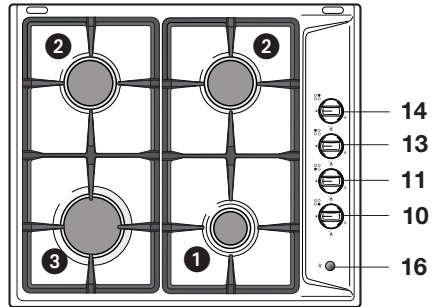

Fig. 1.3b

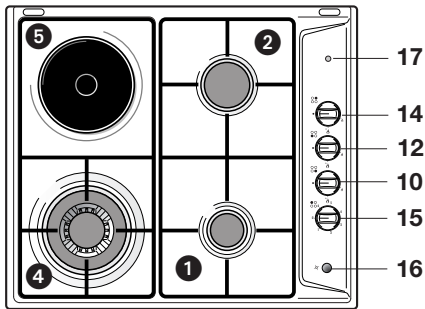

Fig. 1.4a

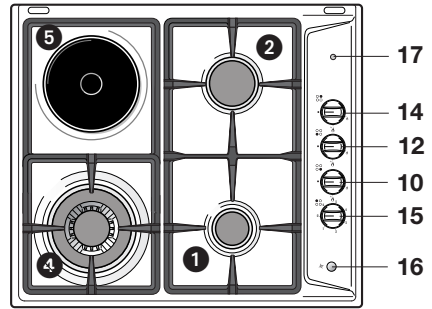

Fig. 1.4b

The appliance has class 3

COOKING POINTS

- | | |
|---|-----------|
| 1. Auxiliary burner (A) | - 1,00 kW |
| 2. Semirapid burner (SR) | - 1,75 kW |
| 3. Rapid burner (R) | - 3,00 kW |
| 4. Triple ring burner (TC) | - 3,50 kW |
| 5. Electric plate - normal Ø 145 mm (1000 W) - rapid (1500 W) | |

CONTROL PANEL

10. Auxiliary burner control knob (1)
11. Rapid burner control knob (3)
12. Triple ring burner control knob (4)
13. Left semirapid burner control knob (2)
14. Right semirapid burner control knob (2)
15. Rear left electrical plate control knob 5
16. Electric gas-lighting device;
 - If the device is not installed, the appliance may be provided with:
 - A gas-lighter incorporated into the knob (☼ symbol beside flame 🔥 - max. heat/max. gas flow).
 - No gas-lighter (no ☼ symbol beside knobs).
17. Electrical plate indicator light



NOTE:

- ✓ If the appliance has a safety valve system fitted (beside every burner is a T-shaped probe, as in Fig. 3.1 - not to be confused with the S-shaped electrode of the gas-lighter), the flow of gas will be stopped if and when the flame should accidentally go out.

GAS BURNERS

Gas flow to the burners is adjusted by turning the knobs (illustrated in figs. 2.1a - 2.1b) which control the valves.

Turning the knob so that the indicator line points to the symbols printed on the panel achieves the following functions:

- full circle ● = closed valve
- symbol  or  = maximum aperture or flow
- symbol  = minimum aperture or flow

- ✓ To reduce the gas flow to minimum, rotate the knob further anti-clockwise to point the indicator towards the small flame symbol.
- ✓ The maximum aperture position permits rapid boiling of liquids, whereas the minimum aperture position allows slower warming of food or maintaining boiling conditions of liquids.
- ✓ Other intermediate operating adjustments can be achieved by positioning the indicator between the maximum and minimum aperture positions, and never between the maximum aperture and closed positions.

Models without safety cut-off valves

Models with electric ignition incorporated into the knobs only

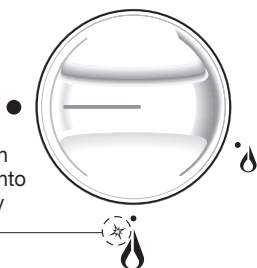



Fig. 2.1a

LIGHTING GAS BURNERS

Models without electric ignition

To light one of the gas burners, hold a flame (e.g. a match) close to the top part of the burner, push in and turn the relative knob in an anti-clockwise direction (fig. 2.3), pointing the knob indicator towards the large flame symbol  (i.e. max. gas flow).

Models fitted with electric spark lighter button

On these cooker tops, to light one of the burners you have to push in and turn the relative knob to the maximum aperture position (large flame symbol ) and press the electric lighter button (fig. 2.2) until the flame has been lit.

Adjust the gas valve to the desired position.

Models with safety cut-off valves

Models with electric ignition incorporated into the knobs only

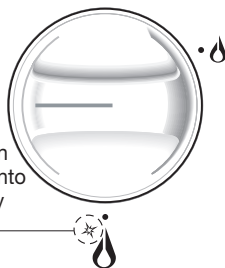

Fig. 2.1b

Models fitted with electric lighter incorporated into the burner knobs

The electric ignition is incorporated in the knobs (★ symbol beside flame 🔥 - max. heat/max. gas flow, figs. 2.1a - 2.1b).

To light one of the gas burners, push in and turn the relative knob to the maximum aperture position (large flame symbol) and hold the knob in until the flame has been lit.

The sparks produced by the lighter situated inside the relative burner will light the flame.

Adjust the gas valve to the desired position.

N.B. If your local gas supply makes it difficult to light the burner with the knob set to maximum, set the knob to minimum and repeat the operation.



Fig. 2.2

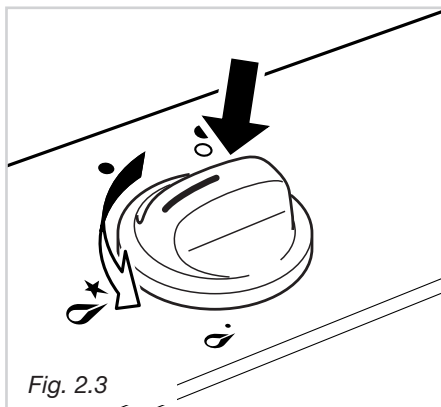

Fig. 2.3

LIGHTING GAS BURNERS FITTED WITH SAFETY VALVE DEVICE

In order to light the burner, you must:

- 1 – Turn the knob in an anti-clockwise direction up to the maximum aperture, push in and hold the knob;
In models with the gas lighter incorporated in the knob, this will light the gas. If there is no mains electrical supply, bring a lighted match close to the burner.
- 2 – For models with push-button lighting only: push the gas-lighter button.
- 3 – Wait about ten seconds after the gaslights before releasing the knob (starting time for the valve).
- 4 – Adjust the gas valve to the desired position.

If the burner flame should go out for some reason, the **safety valve** will automatically stop the gas flow.

To re-light the burner, return the knob to the closed ● position, **wait for at least 1 minute** and then repeat the lighting procedure.

N.B. When the cooktop is not being used, set the gas knobs to their closed positions and also close the cock valve on the gas bottle or the main gas supply line.

CHOICE OF BURNER (fig. 2.4)

The symbols printed on the panel beside the gas knobs indicate the correspondence between the knob and the burner. The most suitable burner is to be chosen according to the diameter and volume capacity of the container to be warmed. It is important that the diameter of the pots or pans suitably match the heating potential of the burners in order not to jeopardise the efficiency of the burners, bringing about a waste of gas fuel.

A small diameter pot or pan placed on a large burner does not necessarily mean that boiling conditions are reached quicker.

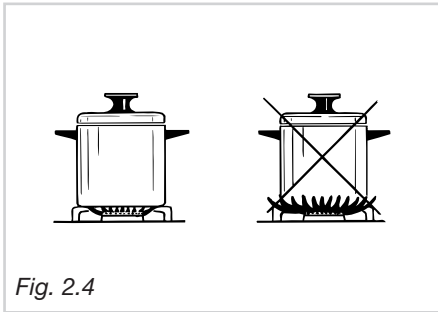

AUXILIARY GRATE FOR SMALL PANS (optional) (fig. 2.5).

This grate is to be placed on top of the (smaller) auxiliary burner when using small diameter pans, in order to prevent them from tipping over.

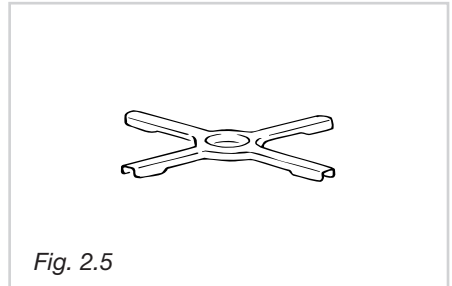

DIAMETERS OF PANS WHICH MAY BE USED ON THE HOBS

BURNERS	MINIMUM	MAX.
Auxiliary	12 cm ⁽¹⁾	14 cm
Semirapid	16 cm	24 cm
Rapid	24 cm	26 cm
Triple-ring	26 cm	28 cm

Maximum diameter for woks: 36 cm

do not use pans with concave or convex bases

(1): with grill for small cookware:
minimum diameter 6 cm

Caution!
the cooking hob becomes very hot during operation.
Keep children well out of reach.

SPECIAL WOK GRILLE - OPTIONAL - (models with triple-ring burner only)

(figs. 2.6a, 2.6b - 2.7a, 2.7b)

This special grille for woks should be placed over the pan-rest for the triple ring burner.

Warning:

- ✓ Using woks without this special grille may cause the burner to malfunction.
- ✓ Do not use the grille for ordinary, flat-bottomed saucepans.

IMPORTANT:

The special grille for wok pans (fig. 2.6b, 2.7b) **MUST BE PLACED ONLY** over the pan-rest for the triple-ring burner.

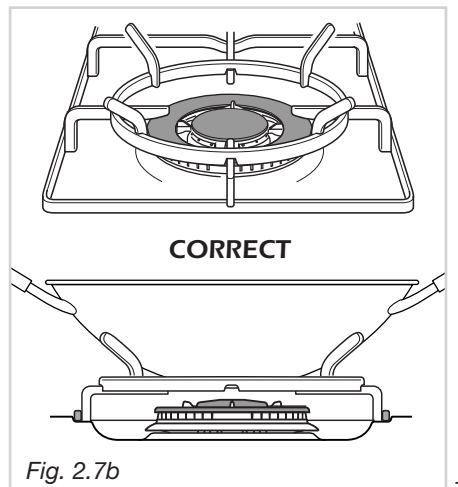
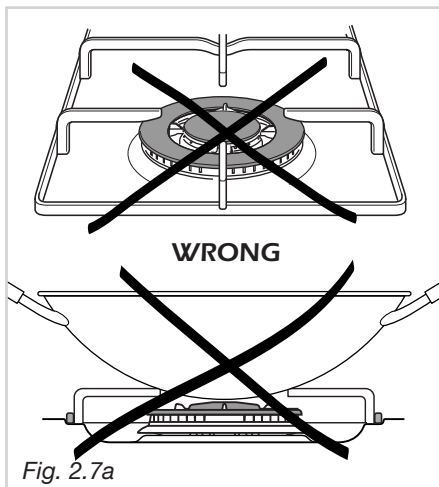
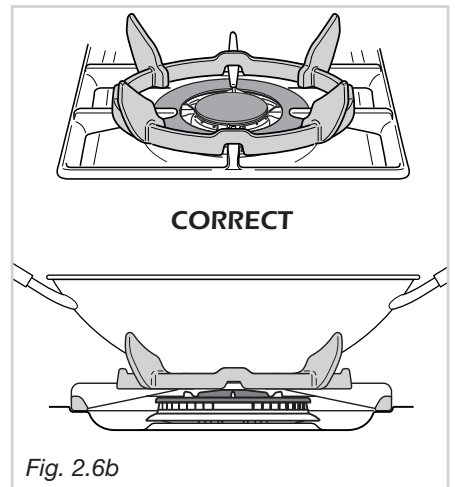
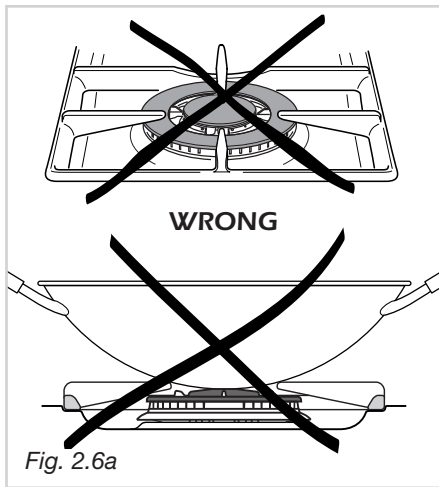

ELECTRIC HOTPLATES

Never cook food directly on the electric hotplates! Always use a saucepan or special container.

NORMAL HOTPLATE

To turn on the electric hotplate, rotate the knob (fig. 2.8) to the desired setting. The numbers from 1 to 6 indicate the operating positions with increasing number corresponding to higher temperature settings.

When the pan comes to the boil, turn the heat down to the level desired.

RAPID HOTPLATE (red dot)

The rapid hotplate control knob is similar to that of the normal hotplate, with 6 selectable heating positions (fig. 2.8).

The characteristics of this hotplate, which is also equipped with a thermostatic cut-off device, make it possible to:

- ✓ achieve the cooking temperature rapidly
- ✓ make full use of its output power using flat-bottomed pans
- ✓ limit the output power with unsuitable saucepans.

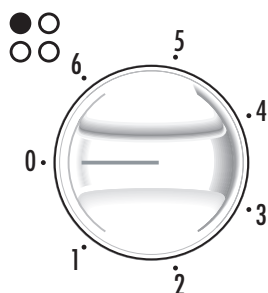

Fig. 2.8

PROPER USE OF THE ELECTRIC HOTPLATE (fig. 2.9)

When the pan comes to the boil, turn the heat down to the level desired.

Remember that the hotplate will continue to produce heat for about five minutes after it has been turned off.

While using the electric hotplate, you must:

- ✓ avoid keeping it on without something on it;
- ✓ avoid pouring liquids on it while it is hot;
- ✓ use flat-bottomed (electric hotplate type) pots and pans only
- ✓ use cooking receptacles which cover as much of the surface of the hotplate as possible.
- ✓ to save electricity, use lids whenever possible.
- ✓ never cook food directly on the hotplate: always use a pan or suitable container.

An indicator light located on the control panel signals that the hotplate is operating.

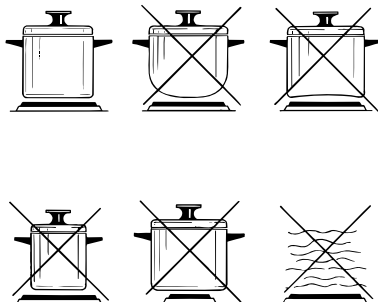
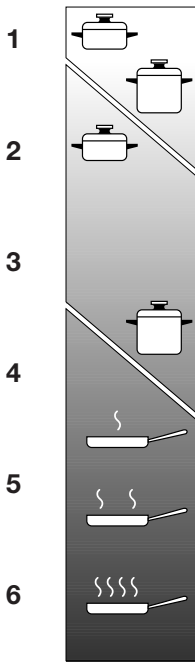

Fig. 2.9

Hob controlled by
7-position
switch
0 - 6



- = Warming
- = Cooking
- = Roasting - Frying

Fig. 2.10

ELECTRIC HOTPLATE USAGE TABLE

<i>Position of switch</i>	TYPE OF COOKING
0	Switched OFF
1 2	For melting operations (butter, chocolate).
2	To maintain food hot and to heat small quantities of liquid (sauces, eggs).
3	To heat bigger quantities; to whip creams and sauces. (vegetables, fruits, soups).
3 4	Slow boiling, i.e.: boiled meats, spaghetti, soups, continuations of steam, cooking of roasts, stews, potatoes.
4	For every kind of frying, cutlets, uncovered cooking, i.e.: risotto.
4 5	Browning of meats, roasted potatoes, fried fish, omelettes, and for boiling large quantities of water.
6	Fast frying, grilled steaks, etc.

**Caution! the cooking hob becomes very hot during operation.
Keep children well out of reach.**

GENERAL ADVICE

- ✓ **Before you begin cleaning you must ensure that the hob is switched off.**
- ✓ It is advisable to clean when the appliance is cold and especially when cleaning the enamelled parts.
- ✓ All enamelled surfaces have to be washed with soapy water or some other non-abrasive product with a sponge and are to be dried preferably with a soft cloth.
- ✓ Avoid leaving alkaline or acid substances (lemon juice, vinegar etc.) on the surfaces.
- ✓ Do not use cleaning products with a chlorine or acidic base.

WARNING

When correctly installed, your product meets all safety requirements laid down for this type of product category. However special care should be taken around the underneath of the appliance as this area is not designed or intended to be touched and may contain sharp or rough edges, that may cause injury.

ENAMELLED PARTS

- ✓ All the enamelled parts must be cleaned with a sponge and soapy water only or other non-abrasive products.
- ✓ Dry preferably with a microfibre or soft cloth.
If acid substances such as lemon juice, tomato conserve, vinegar etc. are left on the enamel for a long time they will etch it, making it opaque.

STAINLESS STEEL ELEMENTS

- ✓ Stainless steel parts must be rinsed with water and dried with a soft and clean cloth.
- ✓ For persistent dirt, use specific non-abrasive products available commercially or a little hot vinegar.
- ✓ **Note: regular use could cause discolouring around the burners, because of the high flame temperature.**

Attention

The appliance gets very hot, mainly around the cooking areas. It is very important that children are not left alone in the kitchen when you are cooking.

Do not use a steam cleaner because the moisture can get into the appliance thus make it unsafe.

CLEANING ELECTRIC HOTPLATES

- ✓ Always clean when the hotplate is tepid.
- ✓ Use a soft cloth, dampened with water, and a little salt. To finish off, use a soft cloth with a little oil.
- ✓ Do not use water, to avoid the formation of rust.

CONTROL KNOB

- ✓ The control knobs may be removed for cleaning but care should be taken not to damage the seal.

GAS TAPS

- ✓ Periodic lubrication of the gas taps must be carried out by specialist personnel only.
- ✓ In the event of operating faults in the gas taps, call the Service Department.

COOKING HOBBS WITH GLASS LID (optional)



Do not shut lid when burner alight.

ATTENTION

- ✓ **Do not lower the glass lid** when the gas burner or electrical plates are still hot and when the oven, installed below the cooking hob, is on or still hot.
- ✓ **Do not lay on the glass lid** hot pans and heavy kitchen utensils.
- ✓ **Dry off any liquid** which may have spilt on the cover before opening it.

BURNERS AND GRIDS

- ✓ These parts can be removed and cleaned with appropriate products.
- ✓ After cleaning, the burners and their flame spreaders must be well dried and correctly replaced.
- ✓ It is very important to check that the burner flame spreader and the cap have been correctly positioned. Failure to do so can cause serious problems.
- ✓ In the models with safety device, check that the probe next to each burner is always clean to ensure correct operation of the safety valves.
- ✓ In appliances with electric ignition keep the electrode clean so that the sparks always strike.
- ✓ **Note: To avoid damage to the electric ignition do not use it when the burners are not in place.**

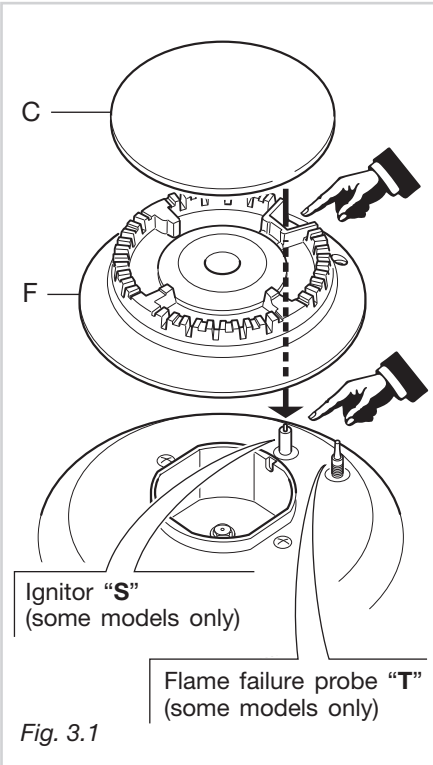

CORRECT REPLACEMENT OF THE BURNERS

It is very important to check that the burner flame spreader "F" and the cap "C" have been correctly positioned (see figs. 3.1 and 3.2).

Failure to do so can cause serious problems.

In appliances with electric ignition, check that the electrode "S" (fig. 3.1) is always clean to ensure trouble-free sparking.

In the models with safety device, check that the probe "T" (fig. 3.1) next to each burner is always clean to ensure correct operation of the safety valves.

Both the probe and ignition plug must be very carefully cleaned.

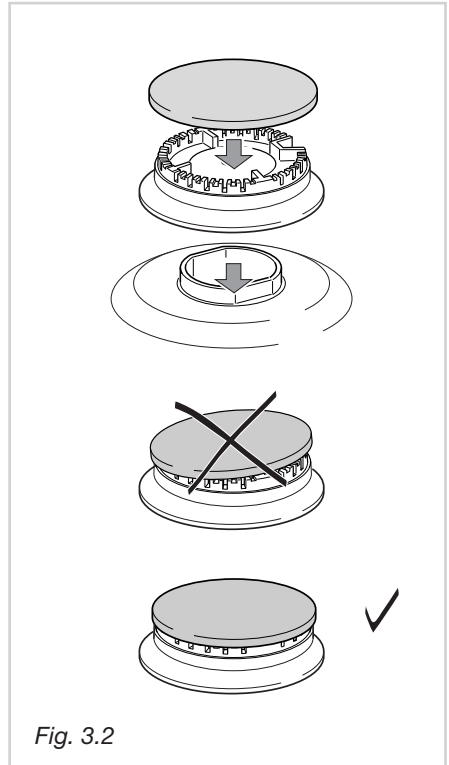

CORRECT POSITION OF TRIPLE RING BURNER

The triple ring burner must be correctly positioned (see fig. 3.3); the burner rib must be fitted in their housing as shown by the arrow.

The burner correctly positioned must not rotate (fig. 3.4).

Then position the cap **A** and the ring **B** (fig. 3.4 - 3.5).

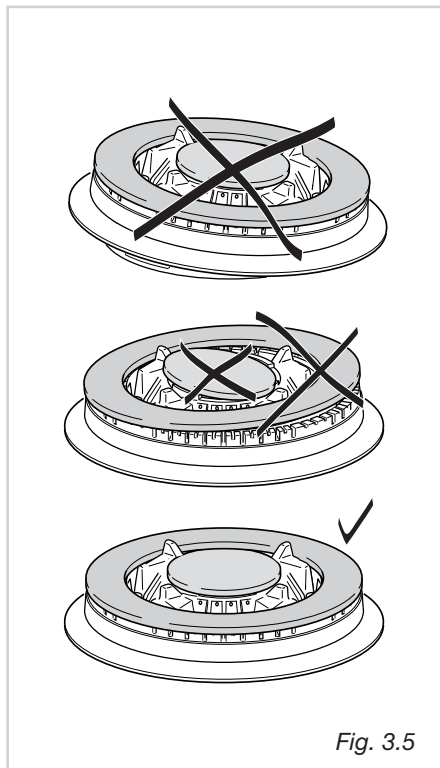
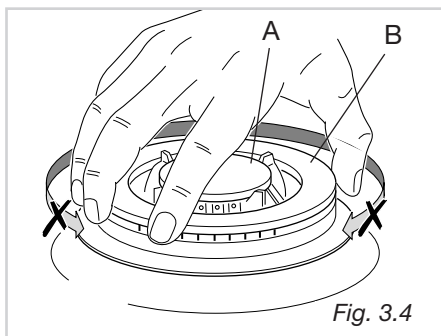
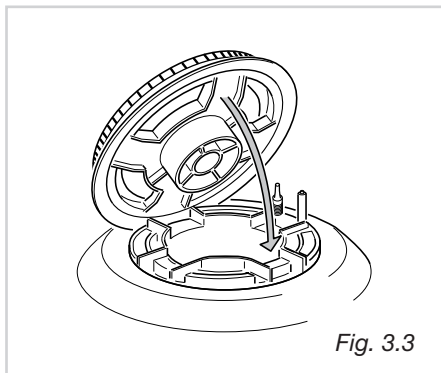

Installation advice

IMPORTANT

- ✓ The appliance should be installed, regulated and adapted to function by a **QUALIFIED INSTALLATION TECHNICIAN**. Failure to comply with this condition will render the guarantee invalid.
- ✓ The appliance must be installed in compliance with the regulations in force in your country and in observation of the manufacturer's instructions.
- ✓ Installation technicians must comply to current laws in force concerning ventilation and the evacuation of exhaust gases.
- ✓ Always unplug the appliance before carrying out any maintenance operations or repairs.

- ✓ *The appliance must be housed in heat-resistant units.*
- ✓ *These tops are designed to be embedded into kitchen fixtures measuring 600 mm in depth.*
- ✓ *The walls of the units must not be higher than work top and must be capable of resisting temperatures of 105 °C above room temperature.*
- ✓ *Do not install the appliance near inflammable materials (eg. curtains).*

WARNING

- ✓ *When correctly installed, your product meets all safety requirements laid down for this type of product category.*
- ✓ *However special care should be taken around the underneath of the appliance as this area is not designed or intended to be touched and may contain sharp or rough edges, that may cause injury.*

TECHNICAL INFORMATION FOR THE INSTALLER

In order to install the cooker top into the kitchen fixture, a hole with the dimensions shown in fig. 4.2 has to be made, bearing in mind the following:

- ✓ within the unit, between the bottom of the cooktop and the upper surface of a shelf there must be a clearance of at least 30 mm.

It is absolutely essential that you place a separator between the base of the cooktop and the built-in unit or the oven;

- ✓ the cooker top must be kept no less than 200 mm away from any side wall (fig. 4.2);

- ✓ the hob must be installed at least 60 mm from the wall;

- ✓ there must be a distance of at least 650 mm between the hob and any wall cupboard or extractor hood positioned immediately above (see fig. 4.1);

- ✓ if the hob is installed over a built-in oven, there must be a distance of at least 30 mm between the two appliances. The two appliances should be connected to the gas supply with independent connections.

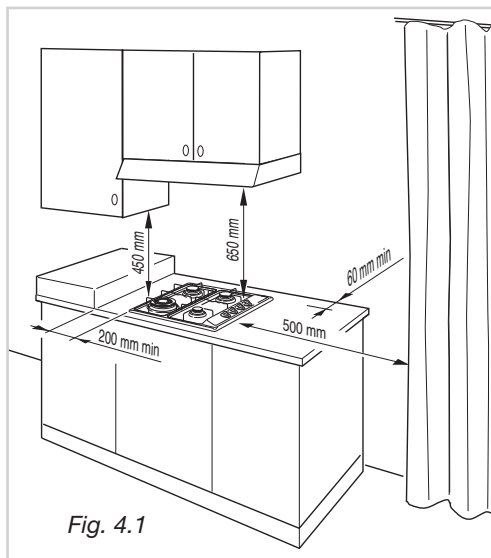

Fig. 4.1

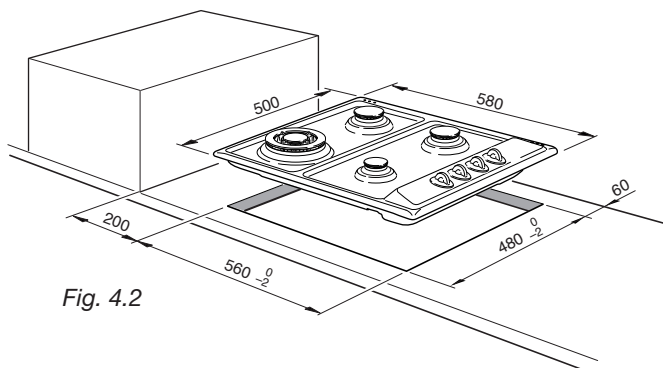

Fig. 4.2

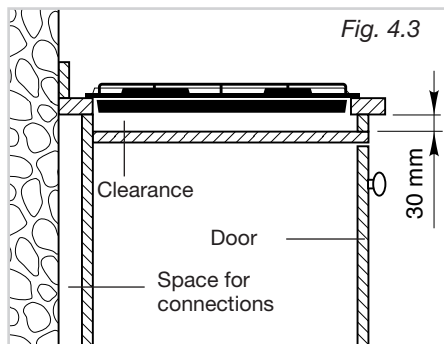

Fig. 4.3

INSTALLATION IN KITCHEN CABINET WITH DOOR (fig. 4.3)

It is recommended that a 30 mm clearance be left between the cooker top and the fixture surface (fig. 4.3).

FASTENING THE INSTALLATION BRACKETS

(figs. 4.4, 4.5, 4.6)

- ✓ Each cooker top is provided with an installation kit including brackets and screws for fastening the top to fixture panels from 2 to 4 cm thick.
- ✓ Turn the cooker top upside down and fasten the brackets “**F** and **R**” to the appropriate socket holes, without tightening the screws “**B**” for the moment.
- ✓ Make sure that the brackets are fastened as shown in figure 4.4.

FASTENING THE COOKER TOP

TOP (figs. 4.5 and 4.6)

- ✓ Spread the sealing material “**D**” out along the fixture hole, making sure that the junctions overlap at the corners.
- ✓ Insert the cooker top into the hole and position it correctly.
- ✓ Adjust the position of the brackets “**F** and **R**”; tooth **C** of the tabs should go into the hole. Tighten screws “**B**” to block the cooker top firmly in position.
- ✓ With a sharp cutter or trimmer knife trim the excess sealing material around the edge of the cooker top. Take care not to damage the bench-top.

Fig. 4.4

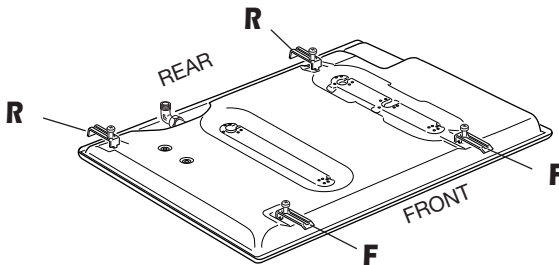

Rear side

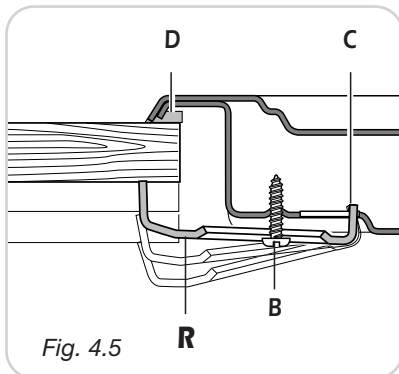

Fig. 4.5

Front side

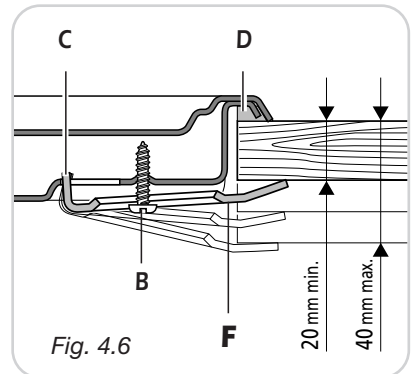

Fig. 4.6

VENTILATION REQUIREMENTS (ALL COUNTRIES EXCEPT UK)

The appliance must be installed in compliance with applicable local regulations concerning ventilation and the evacuation of exhaust gases.

Intensive and prolonged use may require extra ventilation, e.g. opening a window, or more efficient ventilation increasing the mechanical suction power if this is fitted.

CHOOSING SUITABLE SURROUNDINGS

The room where the gas appliance is to be installed must have a natural flow of air so that the gas can burn (in compliance with applicable local regulations).

The flow of air must come directly from one or more openings made in the outside walls with a free area of at least 100 cm² (or refer to applicable local regulations).

If the appliance does not have a no-flame safety device this opening must have an area of at least 200 cm² (or refer to applicable local regulations).

The openings should be near the floor and preferably on the side opposite the exhaust for combustion products and must be so made that they cannot be blocked from either the outside or the outside.

When these openings cannot be made, the necessary air can come from an adjacent room which is ventilated as required, as long as it is not a bed room or a danger area (in compliance with applicable local regulations).

In this case, the kitchen door must allow the passage of the air.

DISCHARGING PRODUCTS OF COMBUSTION

Extractor hoods connected directly to the outside must be provided, to allow the products of combustion of the gas appliance to be discharged (Fig. 4.7).

If this is not possible, an electric fan may be used, attached to the external wall or the window; the fan should have a capacity to circulate air at an hourly rate of 3-5 times the total volume of the kitchen (Fig. 4.8).

The fan can only be installed if the room has suitable vents to allow air to enter, as described under the heading "Choosing suitable surroundings".

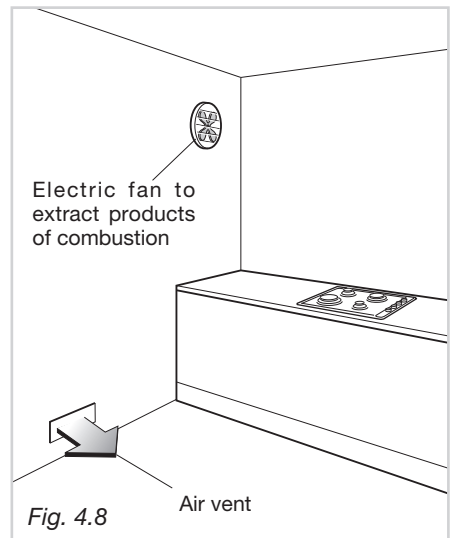
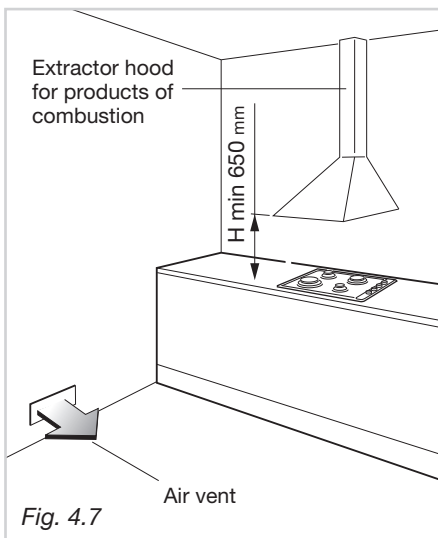

VENTILATION REQUIREMENTS (UNITED KINGDOM ONLY)

- ✓ The appliance should be installed in a room or space with an air supply in accordance with BS 5440:2 2000.
- ✓ For rooms with a volume of less than 5 m³, permanent ventilation through a free area of at least 100 cm² will be required.
- ✓ For rooms with a volume between 5 m³ and 10 m³, permanent ventilation through a free area of at least 50 cm² will be required, unless the room has a door which opens directly to the outside air, in which case no permanent ventilation is required.
- ✓ For rooms with a volume greater than 10 m³, no permanent ventilation is required.

Important !

Regardless of room size, all rooms containing the appliance must have direct access to the outside air via an openable window or equivalent.

- ✓ Where there are other fuel-burning appliances in the same room, BS 5440-2: 2000 should be consulted to determine the correct amount of free area ventilation requirements.
- ✓ The above requirements also allow for use of a gas oven and grill, but you need to consult a qualified engineer if there are other gas-burning appliances in the same room.

GAS INSTALLATION REQUIREMENTS

Important !

- ✓ Before installation, make sure that the local distribution conditions (gas type and pressure) and the adjustment of this appliance are compatible. The appliance adjustment conditions are given on the plate or the label.
- ✓ This appliance must be installed and serviced only by a suitably qualified, registered installer with technical knowledge of both gas installation and electricity. The installation or service must comply with the current editions of the applicable standards, regulations, and codes of practice governing gas and electrical installations.
- ✓ Failure to install the appliance correctly could invalidate any manufacturer's warranty.

This appliance is supplied for use on NATURAL GAS or LPG (check the gas regulation label attached on the appliance).

- ✓ Appliances supplied for use on NATURAL GAS: they are adjusted for this gas only and cannot be used on any other gas (LPG) without modification. The appliances are manufactured for conversion to LPG.
- ✓ Appliances supplied for use on LPG: they are adjusted for this gas only and cannot be used on any other gas (NATURAL GAS) without modification. The appliances are manufactured for conversion to NATURAL GAS.

If the NATURAL GAS/LPG conversion kit is not supplied with the appliance this kit can be purchased by contacting the After-Sales Service.

INSTALLATION & SERVICE REGULATIONS (UNITED KINGDOM ONLY)

This appliance must be installed and serviced only by a suitably qualified and registered person, and in accordance with the current editions of the following standards and regulations or other locally applicable regulations:

- ✓ Gas Safety (Installation & Use) Regulations
- ✓ Building Regulations
- ✓ British Standards
- ✓ Regulations for Electrical Installation

Installation and service of any gas product must be made by a suitably qualified person competent on the type of product being installed or serviced and holding a valid certificate of competence for the work being carried out. Currently the proof of competence is the Accredited Certification Scheme (ACS) or S/NVQ that has been aligned to the ACS.

It is also a requirement that all businesses or self employed installers are members of a class of person approved by the Health and Safety Executive.

Failure to install the appliance correctly could invalidate any manufacturers warranty and lead to prosecution under the above quoted regulation.

CONNECTING THE COOKTOP TO THE GAS SUPPLY

The gas connection fitting (Fig. 5.1) is made up of:

- ✓ the floating nut;
- ✓ the elbow;
- ✓ the gaskets;
- ✓ the conical pipe fitting - to be used for the United Kingdom only or if requested by the applicable local regulations. In this case, before connecting the appliance to the gas supply, fit the conical pipe fitting to the elbow interposing the gasket. If the conical pipe fitting is not supplied with the appliance it can be purchased by contacting the After-Sales Service.

The gas connection must be carried out by an authorised person according to the relevant local standards.

- ✓ If using a flexible hose, make sure it does not come into contact with moving parts.
- ✓ The rear of the chassis is recessed to provide a channel for the appliance inlet pipe.
- ✓ The gas connection fitting can be turned in the direction required (but never in a vertical or horizontal position) after loosening the elbow and floating nut connection.
- ✓ Never attempt to turn the elbow without having first loosened the floating nut.

- ✓ The supplied gaskets guarantee a good seal for the gas connection. We recommend that you replace the gaskets on the slightest sign of wear, deformation or imperfection.
- ✓ **After connecting to the gas mains, check that the couplings are correctly sealed, using soapy solution, but never a naked flame.**

FOR THE UNITED KINGDOM ONLY

Before connecting the appliance to the gas supply fit the conical pipe fitting (if not supplied with the appliance it can be purchased by contacting the After-Sales Service) to the elbow interposing the gasket.

The installation of the gas appliance to Natural Gas or LP Gas must be carried out by a suitably qualified, registered installer. Installers shall take due account of the provisions of the relevant British Standards Code of Practice, the Gas Safety Regulations and the Building Standards (Scotland)(Consolidation) Regulations issued by the Scottish Development Department.

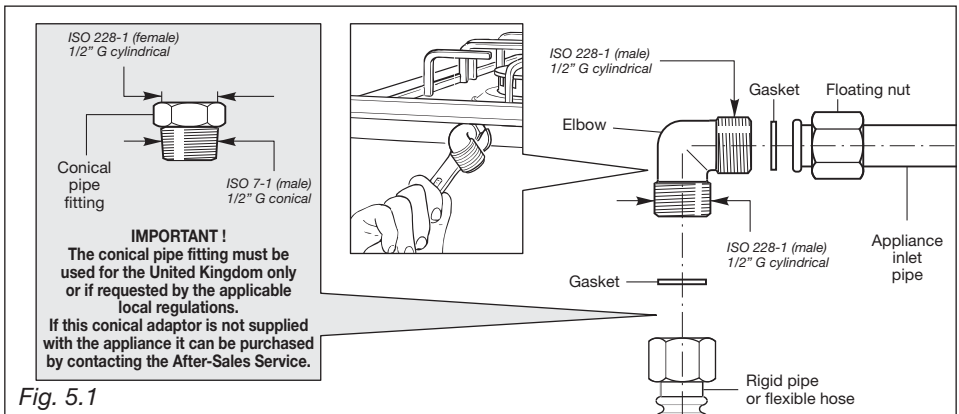

Fig. 5.1

ADDITIONAL GAS CONNECTION REQUIREMENTS (UNITED KINGDOM ONLY)

It is recommended that the gas connection to the appliance is installed with a flexible connecting tube made to BS5386.

Flexible hoses can be used where the sited ambient temperature of the hose does not exceed 70°C. These hoses must be manufactured in accordance with BS669 part 1 and be of the correct construction for the type of gas being used.

Gas hoses designed for natural gas **MUST NOT** be used for supplying LPG gas (LPG gas hoses can be identified by a either a red band or stripe on the rubber outer coating of the hose). The hose should not be crushed or trapped or be in contact with sharp or abrasive edges.

ADDITIONAL GAS CONNECTION REQUIREMENTS (ALL COUNTRIES)

When connecting the cooktop to the gas supply with rigid pipes or a flexible hose (which must comply with BS 669 in the UK), make sure that:

- ✓ You use rigid pipes or a flexible hose compliant with applicable local regulations. The flexible hose shall be of the correct construction for the type of gas being used and of the correct size to maintain the heat output of the appliance.
- ✓ The connection with rigid metal pipes does not cause stress or pressure to the gas piping.
- ✓ The flexible hose is not under tension, twisted, kinked, or too tightly bent, neither while the cooktop is in use nor while it is being connected or disconnected.
- ✓ The flexible hose is not longer than 2000 mm (or refer to applicable local regulations) and does not come into contact with sharp edges, corners, or moving parts, as these may cause abrasion. Use a single flexible hose only; never connect the cooktop with more than one flexible hose.
- ✓ The flexible hose can easily be inspected along its entire length to check its condition; if it has an expiry date, it should be replaced before that date.
- ✓ If using a flexible hose which is not entirely made of metal, make sure that it does not come into contact with any part of the cooktop with a surface temperature of 70°C or above (or refer to applicable local regulations).
- ✓ The rigid pipe or flexible hose is replaced if it shows signs of damage.
- ✓ The flexible hose is not subject to excessive heat by direct exposure to flue products or by contact with hot surfaces.
- ✓ The socket into which the plug of the flexible hose fit is permanently attached to a firmly fixed gas installation pipe and is positioned so that the hose hangs freely downwards.
- ✓ The plug of the flexible hose is accessible after installation, so that it can be disconnected for service or removal.
- ✓ You inform the customer that the rigid pipe or flexible hose should not be subjected to corrosion by cleaning agents.

GAS MAINTENANCE

OPERATIONS TO BE PERFORMED WHEN SUBSTITUTING THE INJECTORS

- ✓ Remove the pan-supports, the burner covers and the knobs;
- ✓ Using a wrench substitute the injectors **J** (Fig. 5.2 - 5.3) with those ones suitable for the type of gas for which it is to be used.

The burners are conceived in such a way so as not to require the adjustment of the primary air.

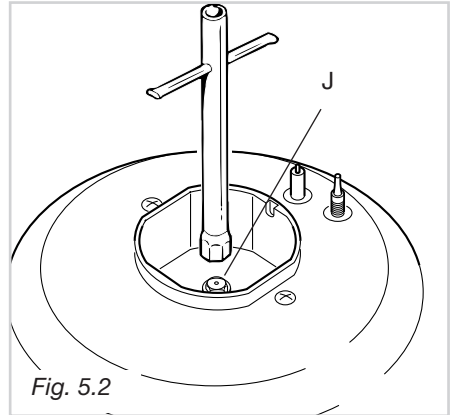

Fig. 5.2

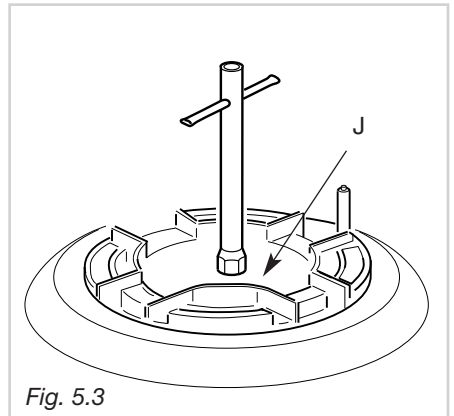

Fig. 5.3

TABLE FOR THE CHOICE OF THE INJECTORS

GB Cat: II 2H 3+			G30/G31 28-30/37 mbar	G 20 20 mbar
FR Cat: II 2E+ 3+			G30/G31 28-30/37 mbar	G20/G25 20/25 mbar
BURNERS	Nominal Power [Hs - kW]	Reduced Power [Hs - kW]	Ø injector [1/100 mm]	Ø injector [1/100 mm]
Auxiliary (A)	1,00	0,30	50	72 (X)
Semi-rapid (SR)	1,75	0,45	65	97 (Z)
Rapid (R)	3,00	0,75	85	115 (Y)
Triple ring (TC)	3,50	1,50	95	135 (T)

AIR VENT NECESSARY FOR GAS COMBUSTION = (2 m³/h x kW)	
BURNERS	Air necessary for combustion [m ³ /h]
Auxiliary (A)	2,00
Semi-rapid (SR)	3,50
Rapid (R)	6,00
Triple ring (TC)	7,00

REGULATING THE BURNER MINIMUM SETTING

When changing from one type of gas to another, the minimum tap output must also be correct, considering that in this position the flame must be about 4 mm long and must remain lit even when the knob is turned sharply from the maximum to the minimum position.

The adjustment is performed with the burner lit, as follows:

- ✓ Turn the knob to the minimum position.
- ✓ Remove the tap knob.

On gas valves provided with adjustment screw in the centre of the shaft (fig. 5.4):

- ✓ Using a screwdriver with max. diameter 3 mm, turn the screw inside the tap until the correct setting is obtained.

On gas valves provided with adjustment screw on the valve body (fig. 5.5):

- ✓ Turn the screw **A** to the correct setting with a screwdriver.

For G 30/G 31 gas, tighten the adjustment screw completely.

LUBRICATING THE GAS TAPS

If one of the gas taps becomes hard to turn, dismantle it, thoroughly clean with petrol and apply special high-temperature grease.

Warning!

These operations must be performed by a specialised engineer.

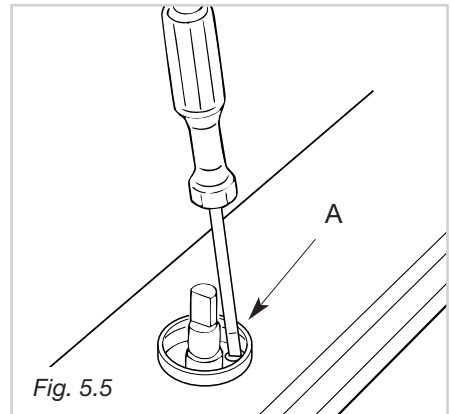
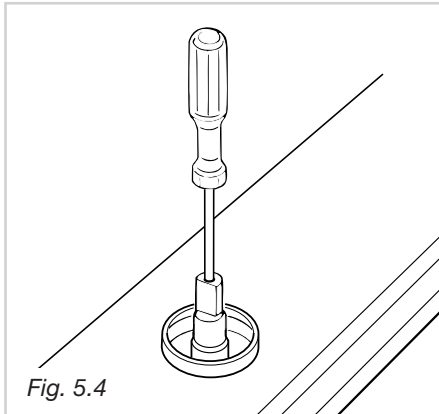

IMPORTANT: The appliance must be installed by a qualified technician according with the current local regulations and in compliance with the manufacturer instructions.

Incorrect installation might cause harm and damage to people, animals or objects, for which the manufacturer accepts no responsibility.

Connection to a good earth wiring system is absolutely essential.

The manufacturer accepts no responsibility for any inconvenience caused by failure to comply with this rule.

Before carrying out any work on the electrical section of the appliance, it must be disconnected from the mains.

DETAILS

- ✓ Connection to the electric power supply must be carried out by a qualified technician and following the appropriate safety regulations;
- ✓ Before carrying out the connection to the power supply, the voltage rating of the appliance (stamped on the appliance identification plate) must be checked for correspondence to the available mains supply voltage, and the mains electric wiring should be capable of handling the hob's power rating (also indicated on the identification plate);
- ✓ If the hob is supplied without a power supply plug and therefore if you are not connecting directly to the mains, a standardized plug suitable for the load must be fitted.
- ✓ The power point must be connected to a suitable earth wiring, in conformity to current safety regulations.
- ✓ It is possible to connect the appliance directly to the mains supply by means of a heavy duty switch with 3 mm minimum distance between the contacts.
- ✓ The power supply cord must not touch against any hot surfaces and must be placed so that its temperature does not exceed 75°C at any point along its length.
- ✓ Once the appliance has been installed, the switch or socket must always be accessible.
- ✓ The appliance must have its own supply; any other appliances installed near it must be supplied separately.
- **N.B. For connections to the mains power supply, never use adapters, reductions or multiple power points as these may overheat and catch fire.**

In the event that installation should require modifications to the mains supply wiring system or if the power plug is not suitable for the type of power point available, it is recommended that a qualified technician be called to carry out substitution.

The technician will also have to verify that the cross-section of the electric cables on the power point match the appliance's power rating.

FOR THE UNITED KINGDOM ONLY FITTING A PROPERLY EARTHED THREE PIN PLUG

A properly earthed three pin plug (fitted with a suitable fuse, BS1362 ASTA approved) must be used. As the colours of the wires in the mains lead of this appliance may not correspond with the coloured markings identifying the terminals in your plug, proceed as follows.

The wire which is coloured GREEN & YELLOW must be connected to the terminal in the plug which is marked with letter **E** or by the Earth symbol or coloured GREEN & YELLOW.

The wire which is coloured BLUE must be connected to the terminal which is marked with the letter **N** or coloured BLACK.

The wire which is coloured BROWN must be connected to the terminal which is marked with the letter **L** or coloured RED.

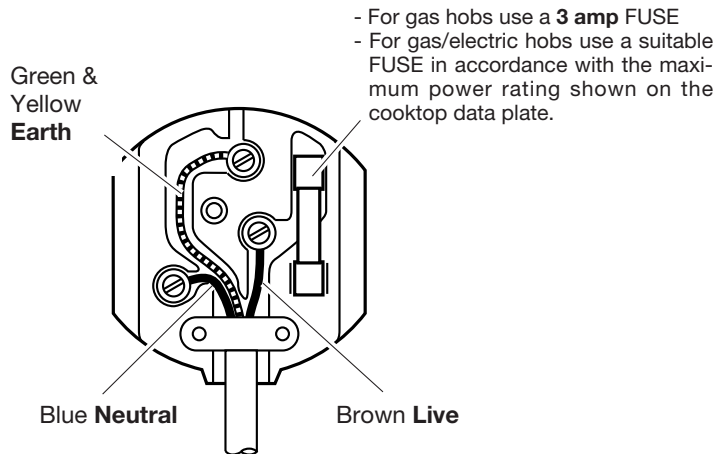

Fig. 6.1

FOR ALL THE COUNTRIES

FEEDER SPECIAL CABLE SECTION Type "HO5V2V2-F" resistance to temperatures of 90°C

230 VAC 50/60 Hz 3 x 0,75 mm² (for gas models)

230 VAC 50/60 Hz 3 x 1,5 mm² (for models with a rating of 1,5 kW at 230 V)

WARNING: If the power supply cable is damaged, it must be replaced only by an authorised service agent in order to avoid a hazard.

- ✓ The supply cable must be replaced with a cable of the same type.
- ✓ The electrical cable must be connected to the terminal board following the diagram of Fig. 6.2.

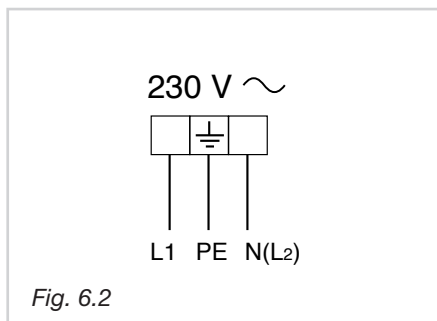



Fig. 6.2



Descriptions and illustrations in this booklet are given as simply indicative. The manufacturer reserves the right, considering the characteristics of the models described here, at any time and without notice, to make eventual necessary modifications for their construction or for commercial needs.